

Business Informatics 2 (PWIN)
WS 2017/2018

Business Process Reengineering (BPR)

Prof. Dr. Kai Rannenber

Deutsche Telekom Chair of Mobile Business & Multilateral Security
Johann Wolfgang Goethe University Frankfurt a. M.

- Introduction
 - Introduction
 - Redesign of Business Processes
- Process-Oriented Modelling
 - Event-driven Process Chains
 - Petri Nets

- Business Process, Business Transaction, Workflow, Process Chain, Operational Flow, ...
- Business Process Reengineering, Business Process Improvement, Business Process Innovation, Business Transformation, Business Engineering, Business Process Optimisation, ...

- **Working definition**

Amount of manual, semi-automated or automated business activities that are executed according to certain rules towards a particular goal.

- Activities are interlinked with each other, with respect to affected people, machines, documents, resources, etc..
- Activities are performed by human and non-human (machine) task managers.
- Tasks are intended as deliverables, as the performance of a task is performed by, performing one or more activities.
- A business process generates a profit or value for customers.
- A collaborative business process activity is run by at least two task managers.

Examples for Business Processes

- An insurance company processing a claim settlement
- A bank processing a loan application
- A tax office processing a tax declaration
- An employee requesting their travel authorisation
- A customer applying for a credit card via the website of a bank
- ...

- Two basic approaches to optimise business processes

Process improvement (e.g. Kaizen)

- Keep existing processes and attempt to continuously improve them



Process renewal (e.g. BPR)

- Radically rethink processes and redesign them from scratch



Business Process Reengineering (BPR)

- **Definition:**

Business Process Reengineering is the **fundamental rethinking** and **radical redesign** of business processes to achieve dramatic improvements in critical contemporary measures of performance, such as cost, quality, service, and speed.

- Information Technology (IT) is a significant enabler for reengineering Business Processes (e.g. workflow management systems, ERP, etc.).

- Basic Steps for Business Process Reengineering:



Dramatically improve performance of business processes rather than merely “optimising” them, i.e.

- Improve **efficiency**, e.g. reduce time to market, provide faster response for customers
- Increase **effectiveness**, e.g. deliver higher process quality
- Achieve **cost saving** in the longer run
- Improve **financial performance**, e.g. in terms of sales, profits or profitability

What does BPR constitute? (1)

An integrated program of change that ...

- delivers **substantial, measurable** improvements, often **rapid ones**;
- usually involves **cultural** and **job/role** changes, which must be managed accordingly;
- is typically 'enabled' through **IS/IT**;
- involves creative thinking (breaking the 'old' rules).

What does BPR constitute? (2)

An integrated program of change that ...

- is sponsored by **top/senior management** rather than the IS/IT function;
- is rather driven **top down** than bottom up;
- begins and ends with **customer value**;
- applies to multiple business functions, departments and/or locations, i.e. it is **process-oriented**.

- Introduction
 - Introduction
 - **Redesign of Business Processes**
- **Process-Oriented Modelling**
 - Event-driven Process Chains
 - Petri Nets

BPR – Identification and Analysis of current Business Processes



- Key activities by Davenport
 - Identification (modelling) of the current main processes
 - Definition of the process boundaries
 - Determination of the strategic relevance of the identified processes
 - Analysis of the needs for improvement of the current processes
- Output: Understanding of “as-is” processes



- Process-Oriented Modelling
 - Description of all relevant aspects of a business process in a specific description language
 - Description languages
e.g. Event-driven Process Chains (EPC) or Petri Nets

- Purpose of Process-Oriented Modelling
 - Understanding and documenting business processes
 - Reducing the complexity of business processes in order to enable a common understanding between stakeholders
 - Enable transparency for business processes

BPR – Design of new Business Processes

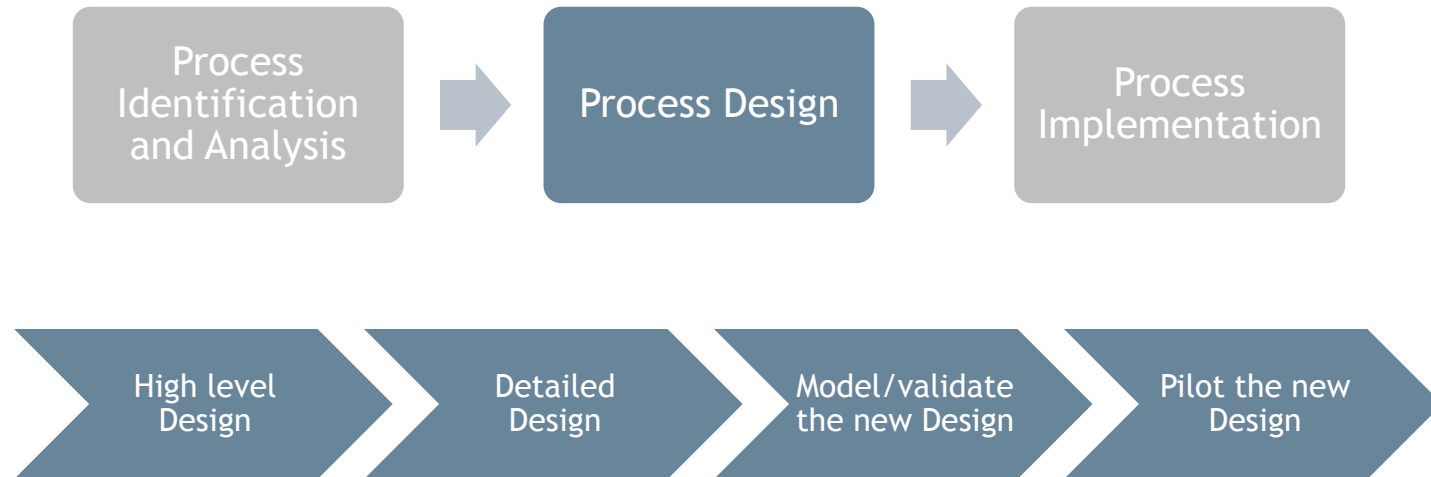

Problems:

- Little evidence about required new design, but many abstract metaphors (e.g. elimination, change of order, parallelisation, integration, avoiding media disruptions,...)
- Creative design process

BPR – Implementation of new Business Processes



BPR – Implementation of new Business Processes – Bottlenecks



- **Organisational Bottlenecks**
 - People as a bottleneck of behavioural change (it takes time for people to change their behaviour)
 - Implementation barriers
 - Special role of top management
 - Coaching the role of process owners
- **ICT Bottlenecks**
 - Isolated solutions
 - Duration of implementation period
 - Adaptation of ICT
- **Interaction between Organisational and ICT Bottlenecks**
 - Implementation of optimised processes without considering ICT aspects is suboptimal.

- Use of ICT can be analysed, reproduced, and adapted.
- The complex arrangement of ICT, processes, and people, which evolved in long learning processes, is not easy to reproduce or adapt.
- BPR does not necessarily lead to dramatic performance improvements.

- Introduction
 - Introduction
 - Redesign of Business Processes
- Process-Oriented Modelling
 - Event-driven Process Chains
 - Petri Nets

- History
 - Semi-formal, graphical description language
 - Developed in 1992 by Prof. Scheer (University of Saarbrücken) and staff.
 - Related ARIS Toolset is very popular in Germany.

- Application
 - EPCs describe processes, i.e. related activity and process sequences.
 - An “event” is defined as the occurrence of an object or as changing a specific object property.
 - Events and activities may be combined with join operators “and”, ”inclusive or”, or ”exclusive or”.

EPC – Basic Graphical Symbols

Event

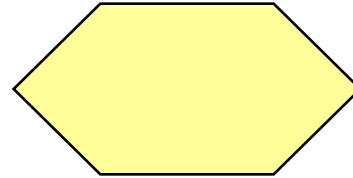

Activity

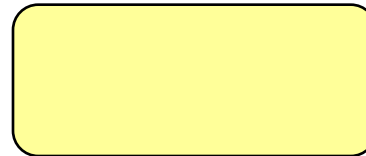

Join operators

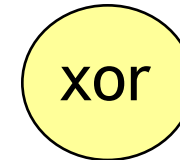
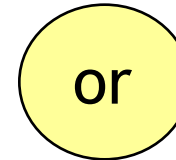
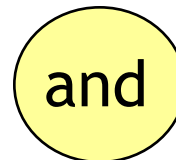

Dependency between
Event and Function



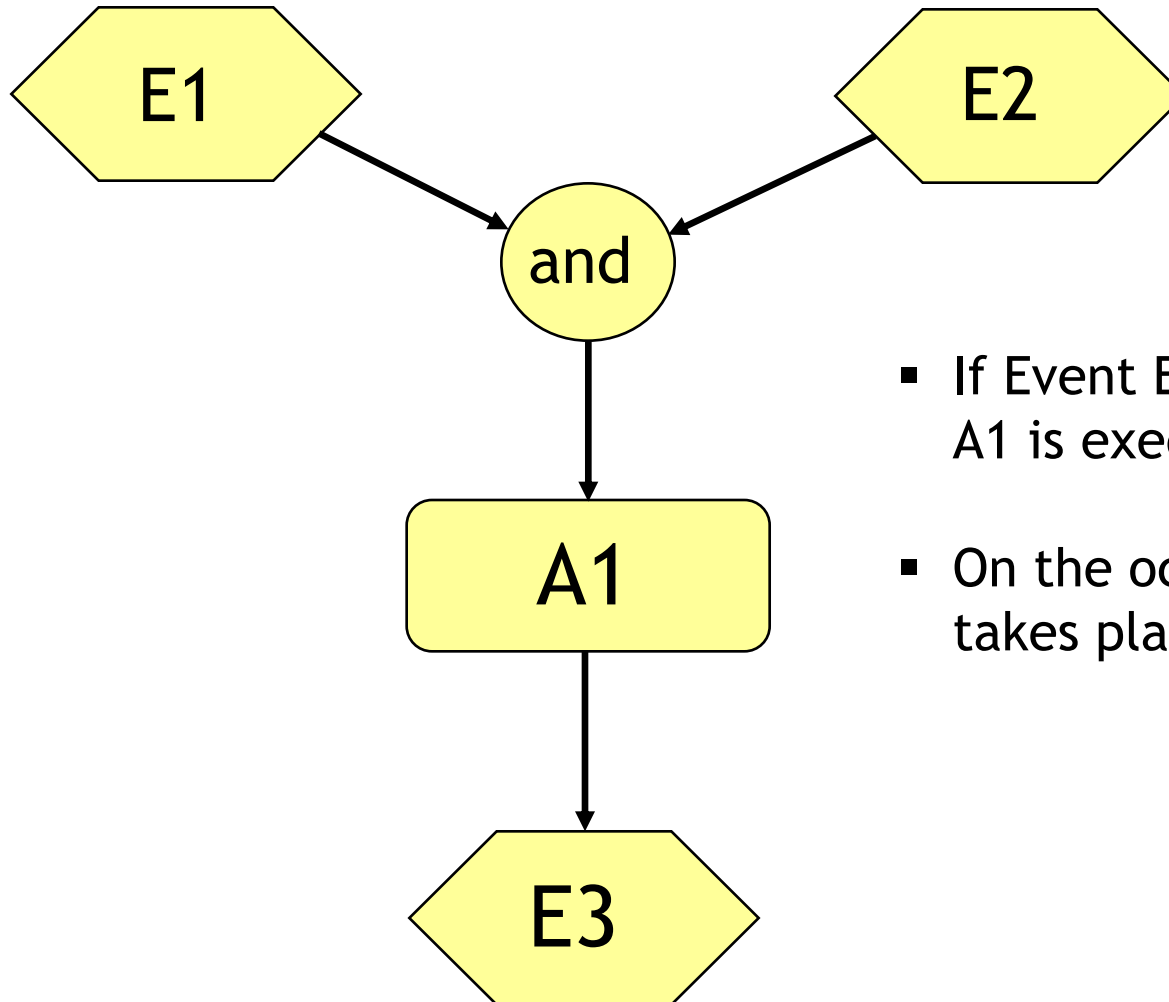

- If Event E1 and E2 occur, activity A1 is executed.
- On the occurrence of A1, E3 takes place.

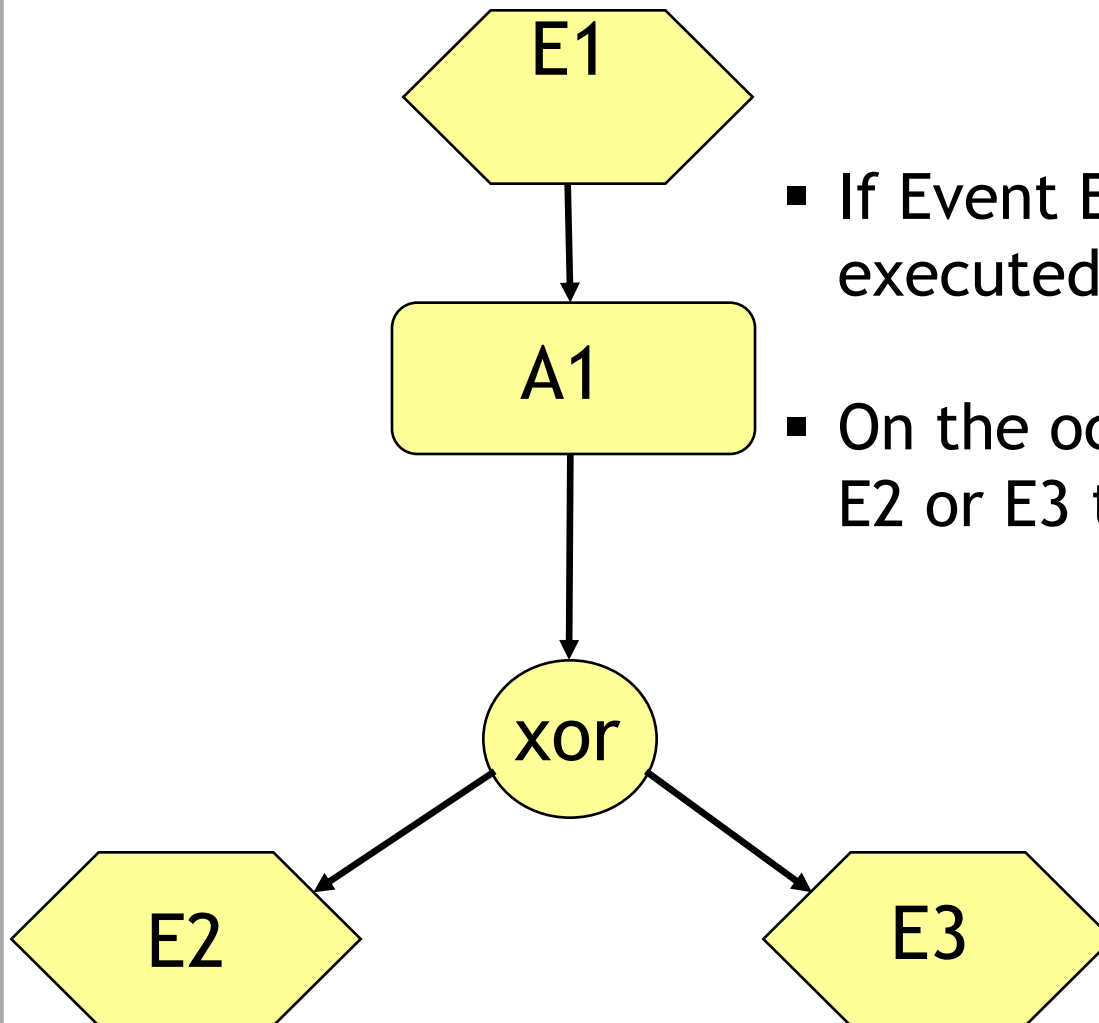

- If Event E1 occurs, Activity A1 is executed.
- On the occurrence of A1, either E2 or E3 takes place.

- Each EPC has to
 - start with at least one event (start event) and to
 - finish with at least one event (final event).
- Exception: Reference to another EPC

EPC – Start and Final Event – Example

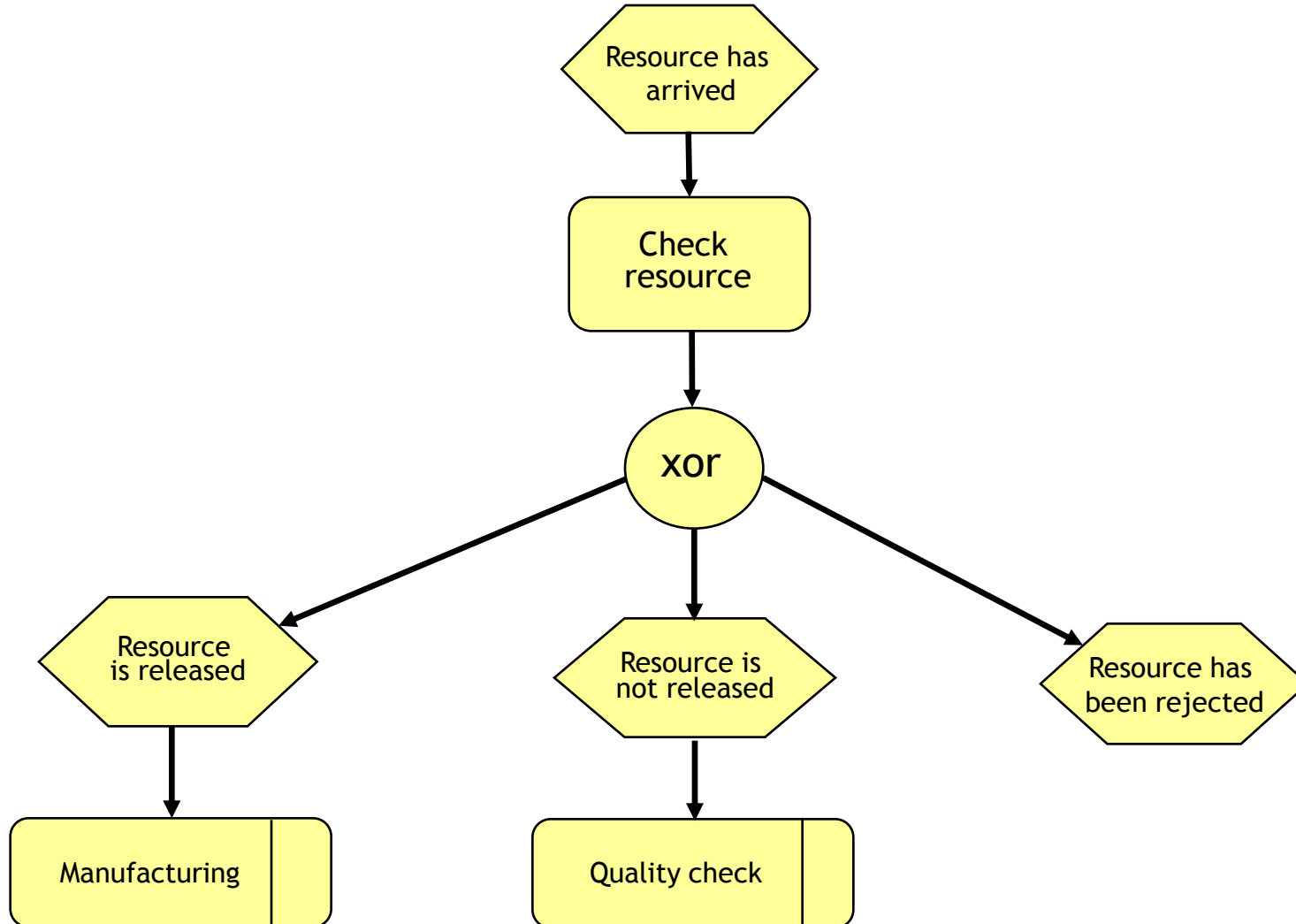

- Activities can be refined hierarchically.
- They can also be associated with
 - responsible organisational units or
 - incoming and outgoing data objects.

EPC – Refinement and Associations

– Graphical Symbols

Data Object / Physical Object

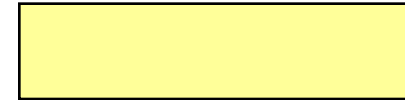

Activity refined by an additional EPC

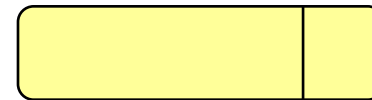

Organisational Unit

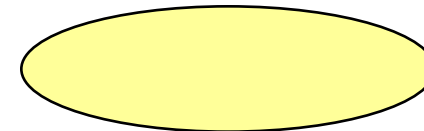

Information flow



Association to Organisational Unit



EPC – Refinement and Associations – Example

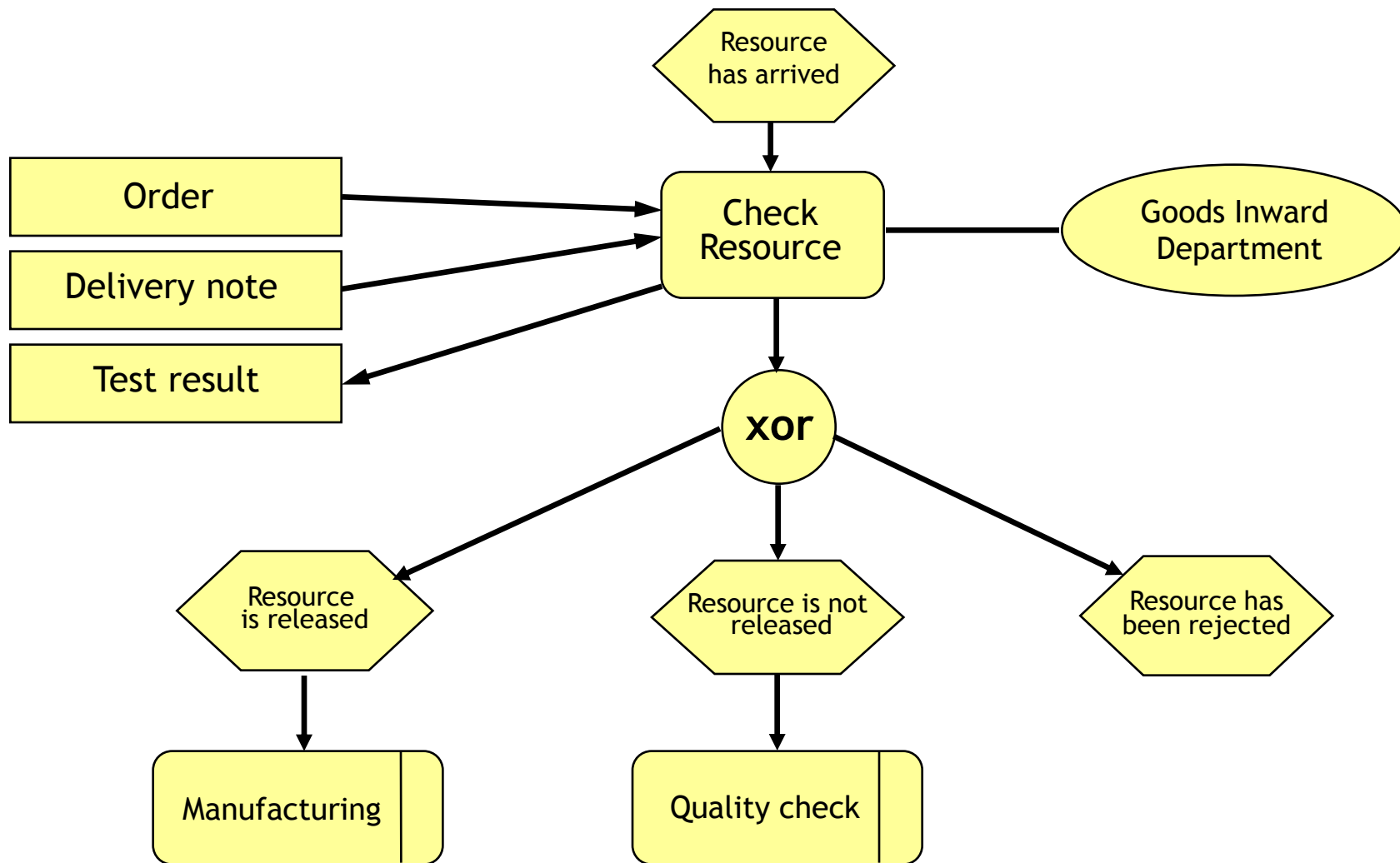

- Simple graphical presentation
- No precise meaning of each symbol, so no formal analysis possible
- Interrelations between objects and activities are often too inadequate for data modeling.
- Fails to distinguish between type and impact of a process

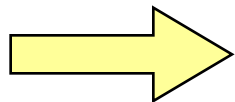

Not directly executable

- Introduction
 - Introduction
 - Redesign of Business Processes
- Process-Oriented Modelling
 - Event-driven Process Chains
 - Petri Nets

- Developed by C.A. Petri (1962)
- The graphical presentation of a Petri net is a bipartite graph.
- There are two kinds of nodes
 - Places: Typically represent resources or partial state of the system
 - Transitions: Represent state transitions and synchronisations
- Arcs in Petri Nets:
 - are directed and
 - always connect nodes of different types.

A **Petri Net graph** (also called *Petri net*) is a 3-tuple , where

- (i) S, T are finite sets
- (ii) $S \cap T = \emptyset$
- (iii) $S \cup T \neq \emptyset$
- (iv) $F \subseteq (S \times T) \cup (T \times S)$

- The elements of S are called *places*, the elements of T are called *transitions*. Places and transitions are also called nodes.
- F is the "flow relation", which constitute a set of arcs.

- Place:

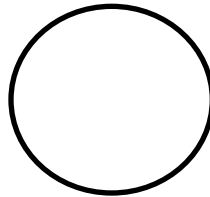

Interpretation:
State

- Transition:



Interpretation:
Activity

- Directed Arc:

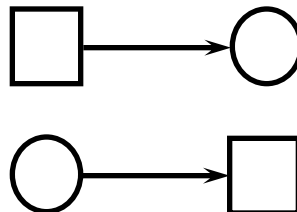

Interpretation:
Input- / Output-Relation

The following figure shows the graphical representation of a network
 $N = (S, T, F)$

$S = \{s1, s2, s3, s4, s5, s6, s7\}$,

$T = \{t1, t2, t3\}$ and

$F = \{(s1,t1), (t1,s2), (t1,s3), (s2,t2), (t2,s5), (s3,t3), (s4,t3), (t3,s6), (t3,s7)\}$

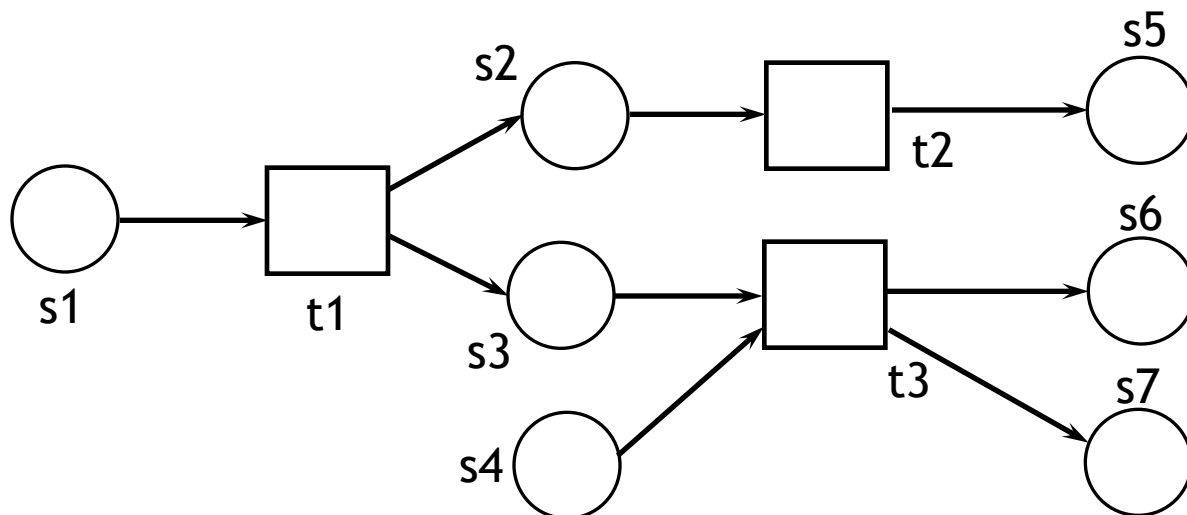

Petri Nets - Process Structures

Sequence

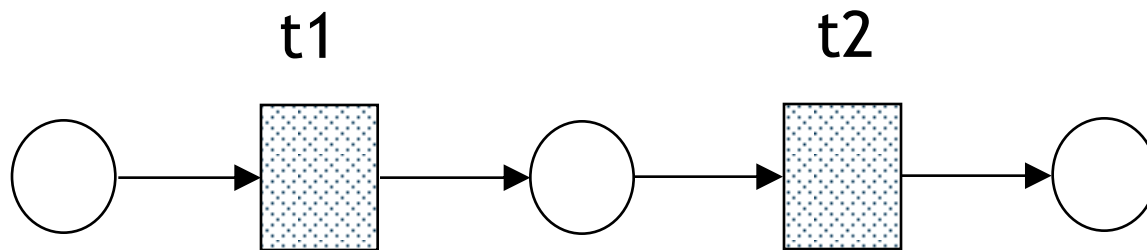

Iteration

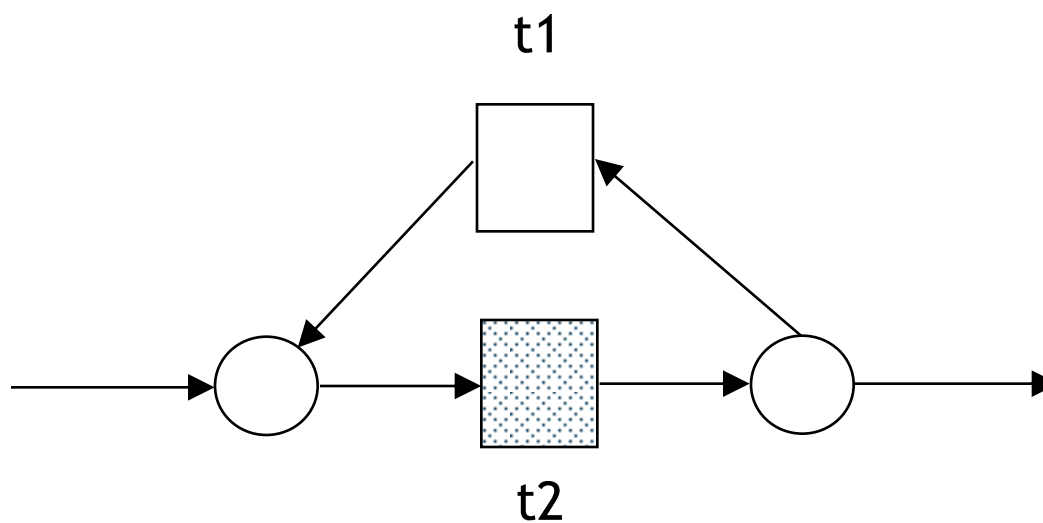

Petri Nets - Process Structures (2)

Concurrency

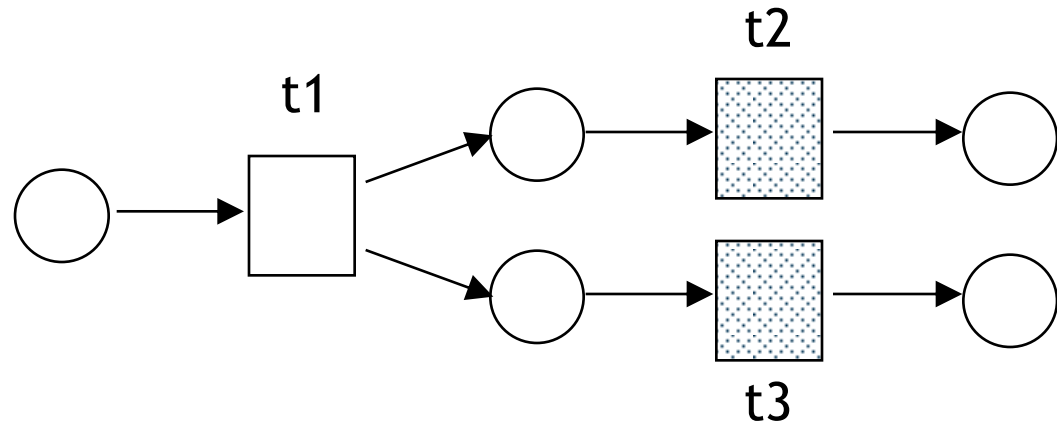

Synchronisation

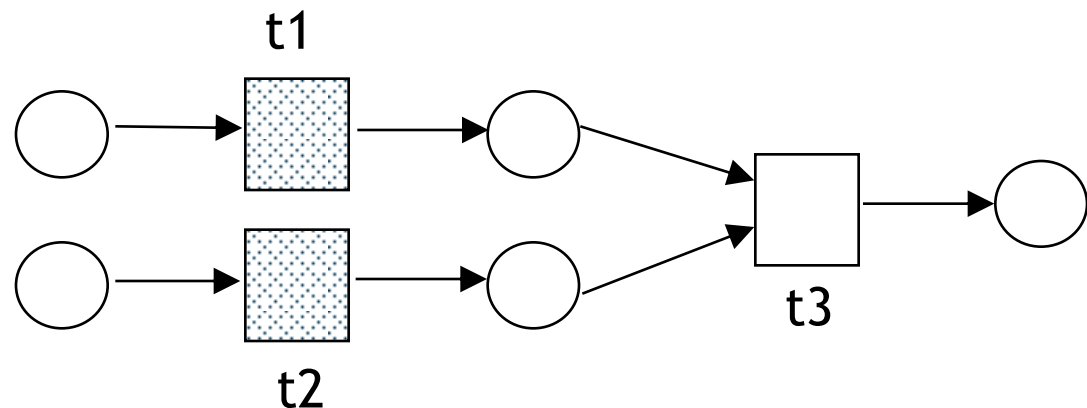

Petri Nets - Process Structures (3)

Selection
(Forward conflict)

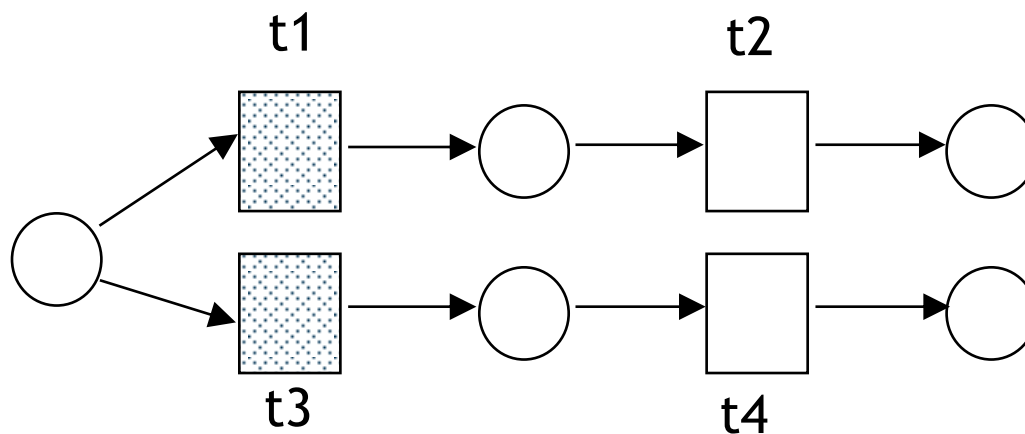

Backwards conflict

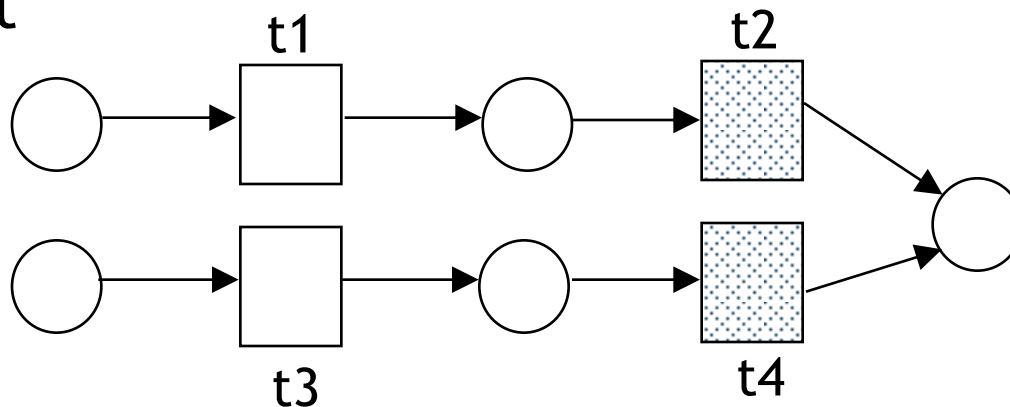

- Integration of object-related aspects
- Directly executable (simulation)
- Allows gradual formalisation
- Mathematically based, can be formally analysed



- Davenport T. (1993): Process Innovation: Reengineering work through information technology. Harvard Business School Press, Boston 1993.
- Laudon, C.; Laudon, J.P.; Schoder D. (2010): Wirtschaftsinformatik´ : Eine Einführung, Pearson Deutschland GmbH, 2. Auflage, 2010.
- Keller G., Nüttgens M., Scheer A.W. (1992): Semantische Prozeßmodellierung auf der Grundlage Ereignisgesteuerter Prozeßketten (EPK). Erschienen in der Reihe: Veröffentlichungen des Instituts für Wirtschaftsinformatik. A.-W. Scheer (Hrsg.). Heft 89, Saarbrücken 1992.
- Hammer, M. and Champy, J. A.: (1993) Reengineering the Corporation: A Manifesto for Business Revolution, Harper Business Books, New York, 1993.
- Kohlbacher, M. (2010): The effects of process orientation: a literature review. Business Process Management Journal, 16(1), S. 135-152, 2010.